

# BRISTAN

## Claret Tap Range

### Installation Instructions & User Guide

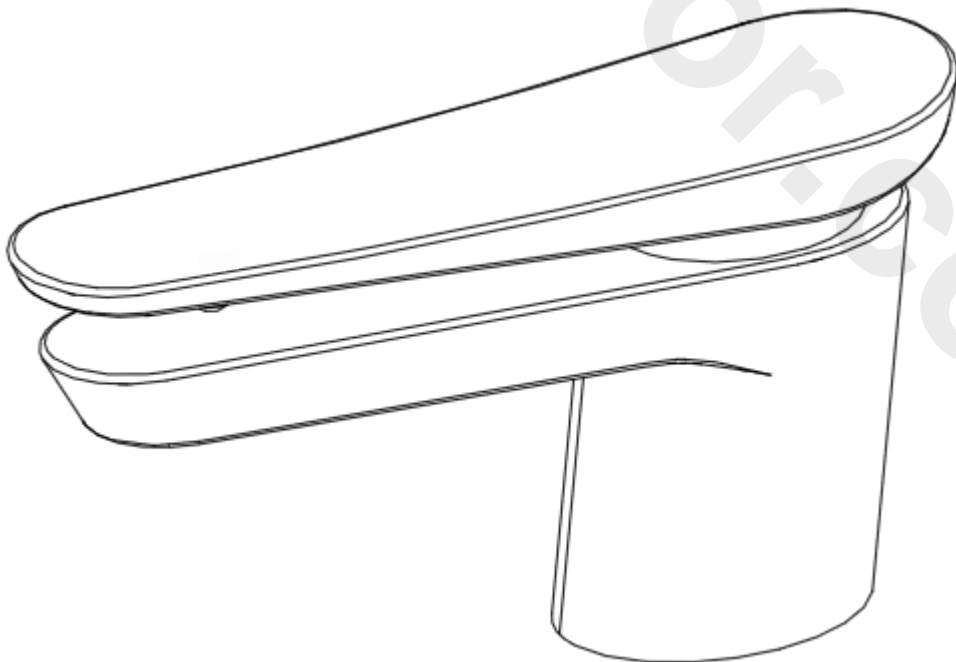

Please keep these instructions for future reference

## Contents

Thank you for choosing Bristan, the UK's leading showers and taps expert. We have designed this product with your enjoyment in mind. To ensure that it works to its full potential, it needs to be fitted correctly. These fitting instructions have been created to give you all of the information you need and, if you need any further help, please do not hesitate to give us a call on 0844 701 6273.

Important Safety Information	03
General Specifications	03
Dimensions	04-05
Installation Requirements	06
Installation	07-12
Basin Mixer & 1 Hole Bath Filler	07
Wall Mounted Basin Mixer & Bath Filler	08-09
Wall Mounted Bath Shower Mixer	10-12
Maintenance	13-14
Troubleshooting	15
Map Of Hard Water Water Regions in the UK	16
Guarantee	17-18
Notes	19

## Important Safety Information

- Please read these instructions thoroughly and retain for future use.
- All products manufactured and supplied by Bristan are safe provided they are installed correctly, used correctly and receive regular maintenance in accordance with these instructions.
- If you are in any doubt about your ability to install this product safely you must employ the services of an experienced qualified plumber.
- Remove all packaging and check the components for damage before starting installation.
-  Before starting any installation please consider the following: Prior to drilling into walls, check that there are no hidden electrical wires, cables or water supply pipes. This can be checked with the aid of an electronic detector.
- If power tools are used do not forget to:
  - Wear eye protection
  - Unplug equipment after use
- This product **must** not be modified in any way as this will invalidate the guarantee.
- These fittings need to be installed in accordance with and meet the requirements of the Water Supply (Water Fittings) Regulations 1999 and Scottish Byelaws 2004.

## General Specifications

Operating pressure range (bar)	Min	Max
1 Hole Bath Filler	1.5	5.0
Basin Mixer (No Waste)	0.2	5.0
Wall Mounted Basin Mixer	1.0	5.0
Wall Mounted Bath Filler	0.3	5.0
Wall Mounted Bath Shower Mixer	1.0	5.0

Maximum static pressure – 10.0 bar

NOTE:- Nominally equal (balanced) inlet supply pressures are recommended for optimum Performance of mixer taps.

Designed to comply with BS EN 200 for single taps / combination taps for water systems of type 1 and 2 general technical specifications; and to be used within systems designed to BS 6700.

BS 6700 recommends the temperature of stored water should never exceed 65°C. A stored water temperature of 60°C is considered sufficient to meet all nominal requirements and will minimise the build up of lime scale in hard water areas.

## Dimensions

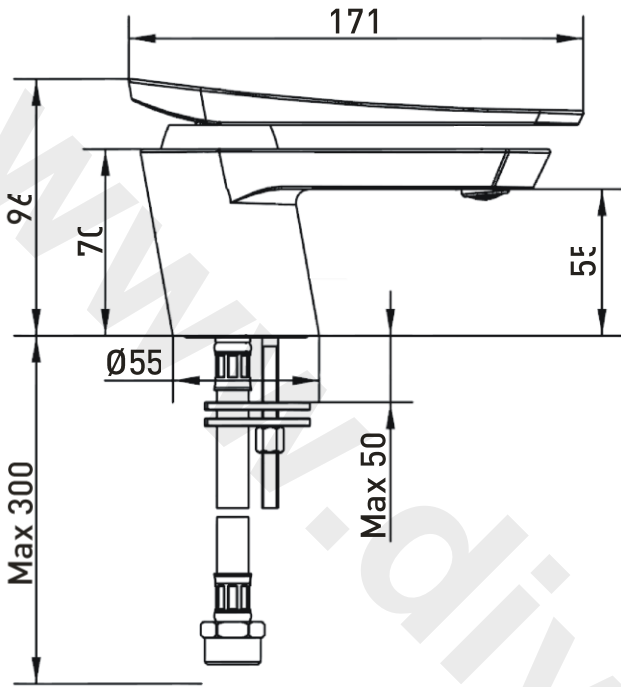

Basin Mixer

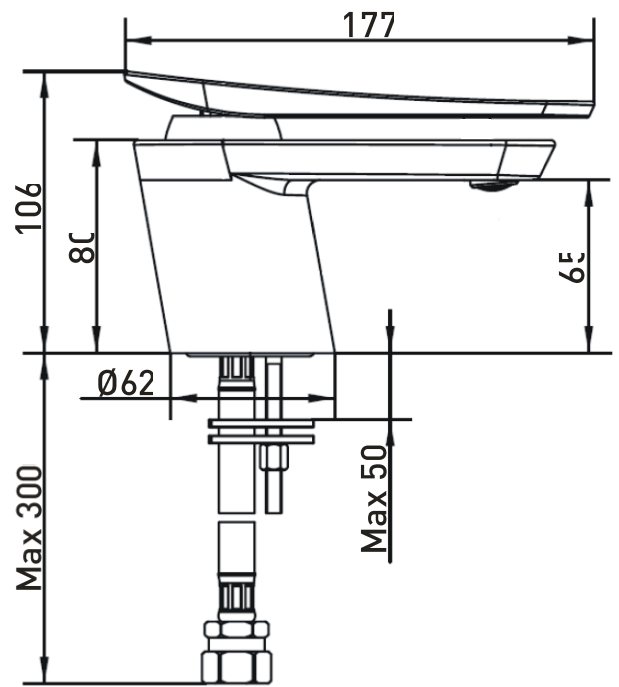

1 Hole Bath Filler

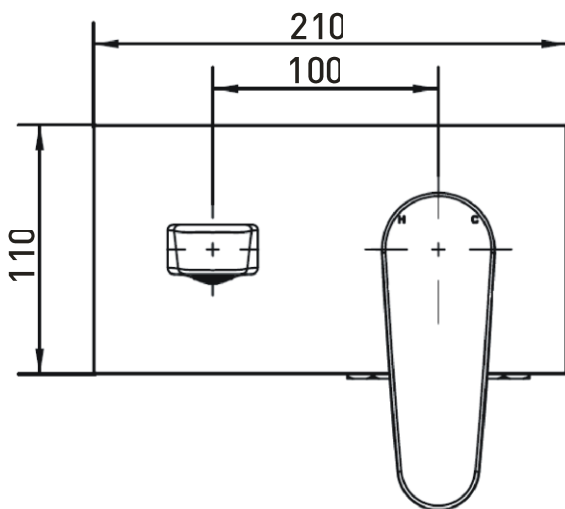

Wall Mounted Basin Mixer

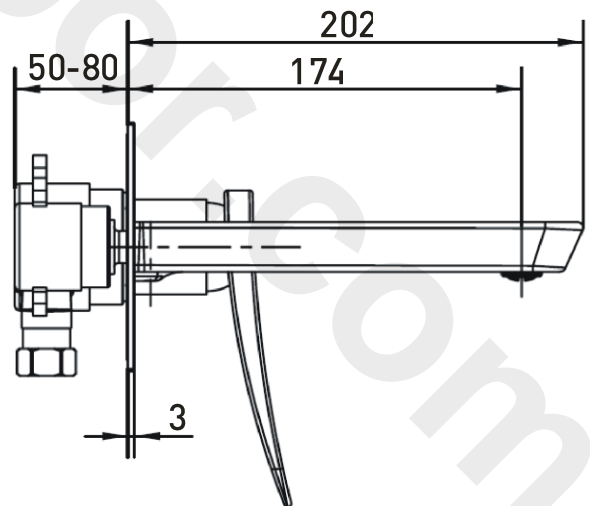

## Dimensions Cont.

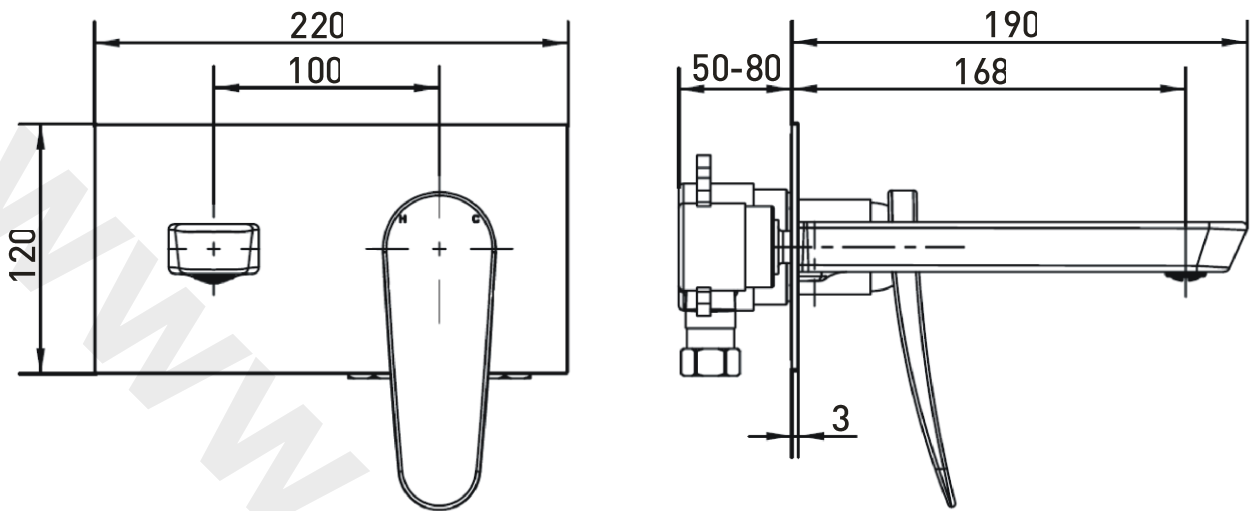

Wall Mounted Bath Filler

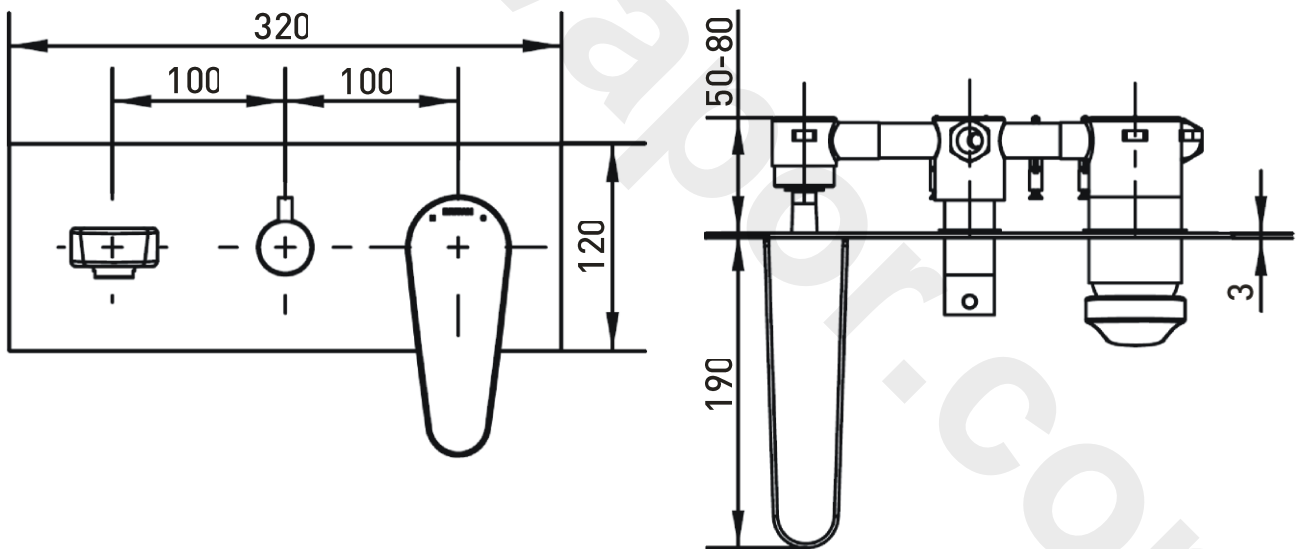

Wall Mounted Bath Shower Mixer

## Installation Requirements

### IMPORTANT - PLEASE READ

This/these fitting/fittings needs/need to be installed in accordance with the following Installation Requirements and Notes (IRN) to ensure they meet the requirements of the Water Supply (Water Fittings) Regulations 1999 and the Scottish Byelaws 2004.

**IRN R001: CLR BASNW C, CLR WMBAS C, CLR WMBF C, CLR WMBSM C, CLR 1HBF C**

See text of entry for Installation Requirements or Notes.

**IRN R005: CLR WMBF C, CLR WMBSM C**

This tap or combination tap assembly has a Type AUK2 air gap and is therefore only suitable for installation in domestic premises or in other premises to protect against a backflow risk up to a Fluid Category 3, unless additional backflow protection for the higher risk is included in the installation.

**IRN R006: CLR BASNW C, CLR WMBAS C, CLR 1HBF C**

This tap or combination tap is installed so that its base is no lower than the spillover level of the receiving vessel (for example, a sink or washbasin), a Type AUK3 air gap is achieved which permits installation of the tap in any premises where backflow protection up to Fluid Category 5 is required at the tap.

**IRN R010: CLR BASNW C, CLR WMBAS C, CLR WMBF C, CLR 1HBF C – Schedule 2-15 (1)**

Water supplies shall be a reasonably balanced pressures from a common source (e.g. hot and cold supplies both from the same storage or both from a supply pipe). Where the fitting is supplied from unbalanced supplies (e.g. hot and cold supplies from separate sources) a **'Listed' single check valve** or some other no less effective backflow prevention device shall be fitted immediately upstream of both hot and cold water inlets.

**IRN R030: CLR WMBSM C – Schedule 2-15 (1)** Multiple inlet fittings installed in domestic premises or in other premises to protect against a backflow risk up to a Fluid Category 3, incorporating a self cancelling diverter acceptable as a backflow prevention device (HC) and having an AUK2 or AUK3 air gap, shall be installed in accordance with IRN R010.

Multiple inlet fittings installed in premises other than domestic to protect against a backflow risk up to a Fluid Category 5, incorporating a self cancelling diverter acceptable as a backflow prevention device (HC only) and having an AUK2 or AUK3 air gap, shall be installed in accordance with IRN R010. Alternatively the fitting shall be supplied in accordance with IRN R040 unless the shower head is constrained above the spill-over lever of the bath, wash basin or shower tray.

## Installation

### Basin Mixer (No Waste) & 1 Hole Bath Filler

1. Identify all components are present prior to starting installation.
2. Ensure that the washer (9) is fitted to the underside of the tap body (7) before fitting to the basin/bath. Secure the 'C' shaped rubber washer (10) and metal plate (11) into position on the underside of the basin/bath, using the threaded rods and nuts (12).
3. Fit the inlet connection pipes (13) by hand only (DO NOT OVERTIGHTEN) to the fitting and connect the hot and cold supplies.
4. Connect the hot and cold water supplies to the connecting pipes
5. Turn on the water and fully open the mixer, allowing it to run for a few minutes and check all joints and connections for any leaks.

- |     |                         |    |
|-----|-------------------------|----|
| 1.  | Grub Screw              | x1 |
| 2.  | Lever Handle            | x1 |
| 3.  | Leaver Handle Spacer    | x1 |
| 4.  | Shroud                  | x1 |
| 5.  | Cartridge Retaining Nut | x1 |
| 6.  | Cartridge               | x1 |
| 7.  | Tap Body                | x1 |
| 8.  | Anti-Splash Assembly    | x1 |
| 9.  | Washer                  | x1 |
| 10. | C Shaped Rubber Washer  | x1 |
| 11. | C Shaped Metal Plate    | x1 |
| 12. | Fixing Rods             | x2 |
| 13. | Connecting Pipes        | x2 |

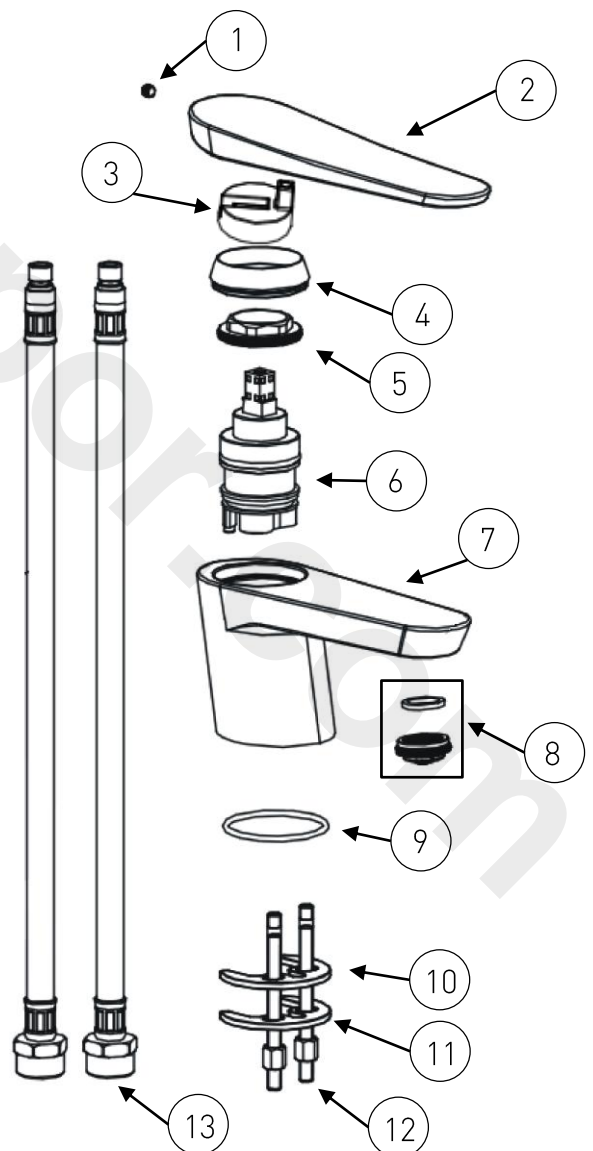

### Wall Mounted Basin Mixer / Bath Filler

1. Identify all components are present prior to starting installation using the diagram overleaf, and be sure to refer to the dimensions on pages 4 & 5 for minimum and maximum wall cavity depths.
2. Offer the mixer body (7) up to the wall and once in the desired position, mark and drill holes for the fixings (12)  
**IMPORTANT:** Before drilling into walls, check that there are no hidden electrical wires, cables or water supply pipes. This can be checked with the aid of an electronic detector. If power tools are used do not forget to wear eye protection & unplug equipment after use
3. Fit the mixer body (7) to the wall and connect water supplies using the nut and olive (13). Any further tiling required, should be completed at this stage,

**NOTE:** The tiles should not restrict access to the valve in order to allow for servicing of the product if necessary.

4. Push concealing plate (8), complete with seal (9), over the valve body and push towards the tiled surface.

**TIP:** Use a thin line of silicone based sealant around the back edge of the concealing plate to create a tight water seal.

5. Push the spout (17) on to the pre-fitted spout connection kit (14); ensuring that both O-rings locate within the spout, and both of the locking grub screws (15) fit into place, via the 2 small holes in the concealing plate (8). Tighten grub screw on the underside of spout to secure into place.
6. Turn on the water and fully open the mixer, allowing it to run for a few minutes and check all joints and connections for any leaks

1.	Handle	x1	10.	O-Ring	x1
2.	Cartridge Retaining Nut	x1	11.	O-Ring	x1
3.	Shroud	x1	12.	Screw & Wall Plug Pack	x1
4.	Cartridge	x1	13.	Nut & Olive	x1
5.	Mixer Body Sleeve	x1	14.	Spout Connection Kit	x1
6.	O-Ring	x1	15.	Locking Grub Screws	x2
7.	Mixer Body	x1	16.	Spout Grub Screw	x1
8.	Concealing Plate	x1	17.	Spout	x1
9.	Concealing Plate Seal	x1	18.	Anti-Splash	x1
			19.	Handle Grub Screw	x1



## Installation cont.

### Wall Mounted Basin Mixer / Bath Filler

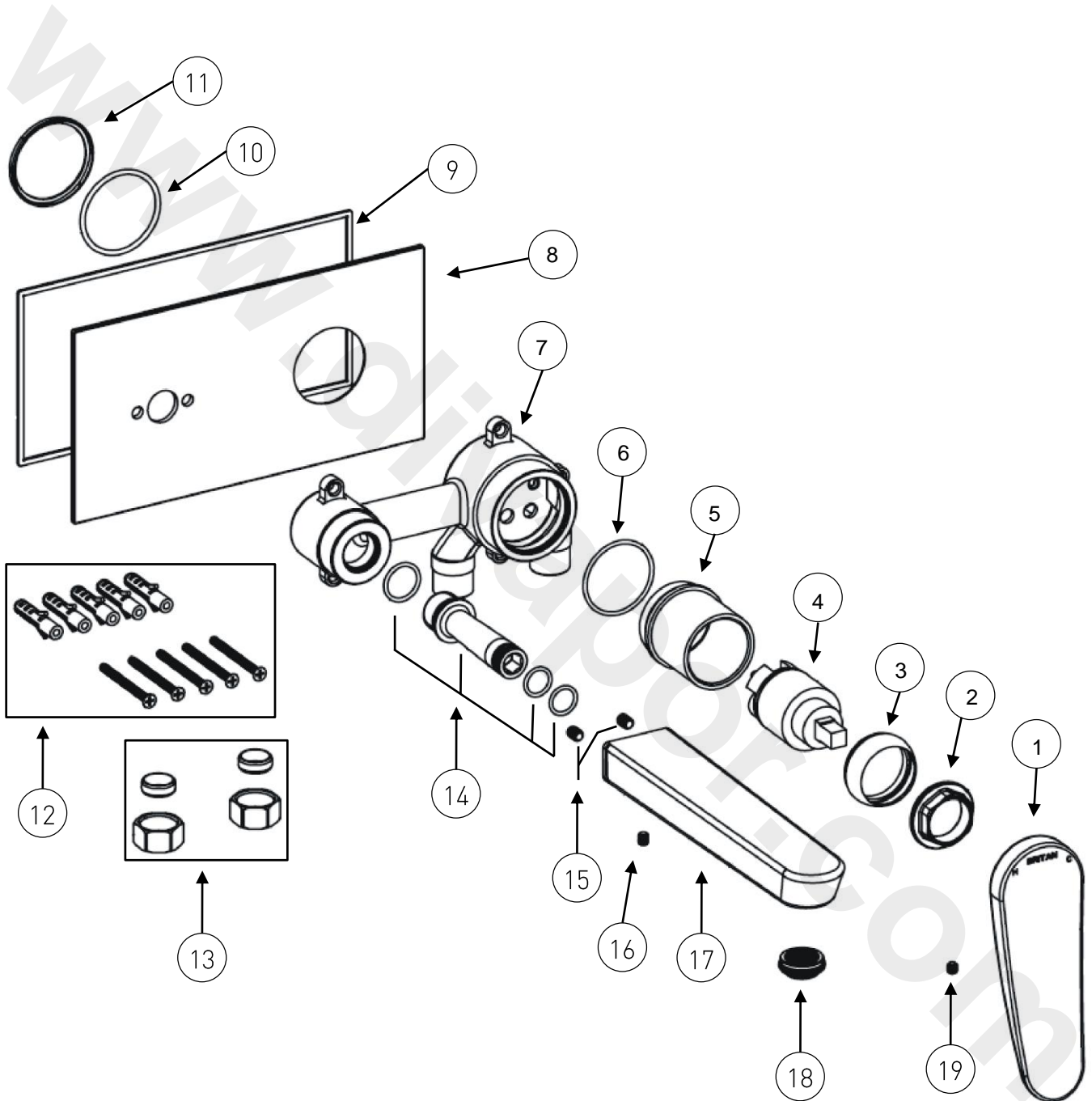

## Installation cont.

### Wall Mounted Bath Shower Mixer

1. Identify all components are present prior to starting installation using the diagram overleaf, and be sure to refer to the dimensions on pages 4 & 5 for minimum and maximum wall cavity depths.
2. Offer the mixer body (7) up to the wall and once in the desired position, mark and drill holes for the fixings (23)  
  
**IMPORTANT:** Before drilling into walls, check that there are no hidden electrical wires, cables or water supply pipes. This can be checked with the aid of an electronic detector. If power tools are used do not forget to wear eye protection & unplug equipment after use
3. Fit the mixer body (7) to the wall and connect water supplies using the nuts and olives (24); and install the wall outlet connection (see page 12),.

**NOTE:** Any further tiling required, should be completed at this stage, The tiles should not restrict access to the valve in order to allow for servicing of the product if necessary.

4. Push concealing plate (8), complete with seal (9), over the valve body and up towards the tiled surface.

**TIP:** Use a thin line of silicone based sealant around the back edge of the concealing plate to create a tight water seal.

5. Push the spout on to the body ensuring both O-rings locate within the spout, and both locking pins (16) lock into place, via the 2 small holes on either side of the spout connection. Tighten grub screw on the underside of spout to secure into place.

**NOTE:** This fitting incorporates a diverter feature. Simply turn the diverter knob via the lever, in order to change the setting from handset only (upright position), a combination of handset and bath fill (central position), and bath fill only (downwards position).

## Installation cont.

### Bath Shower Mixer

1.	Handle	x1	13.	Hose	x1
2.	Shroud	x1	14.	Handset	x1
3.	Retaining Nut	x1	15.	Spout Connections	x1
4.	Cartridge	x1	16.	Spout Locking Pins	x1
5.	Sleeve	x1	17.	Spout	x1
6.	O-Ring	x1	18.	Grub Screw	x1
7.	Mixer Body	x1	19.	Anti-Splash	x1
8.	Concealing Plate	x1	20.	Diverter Assembly	x1
9.	Plate Seal	x1	21.	Diverter Knob	x1
10.	O-Ring	x1	22.	Grub Screw	x1
11.	O-Ring	x1	23.	Screw & Wall Plug Pack	x1
12.	Handset Holder	x1	24.	Nut & Olive	x3

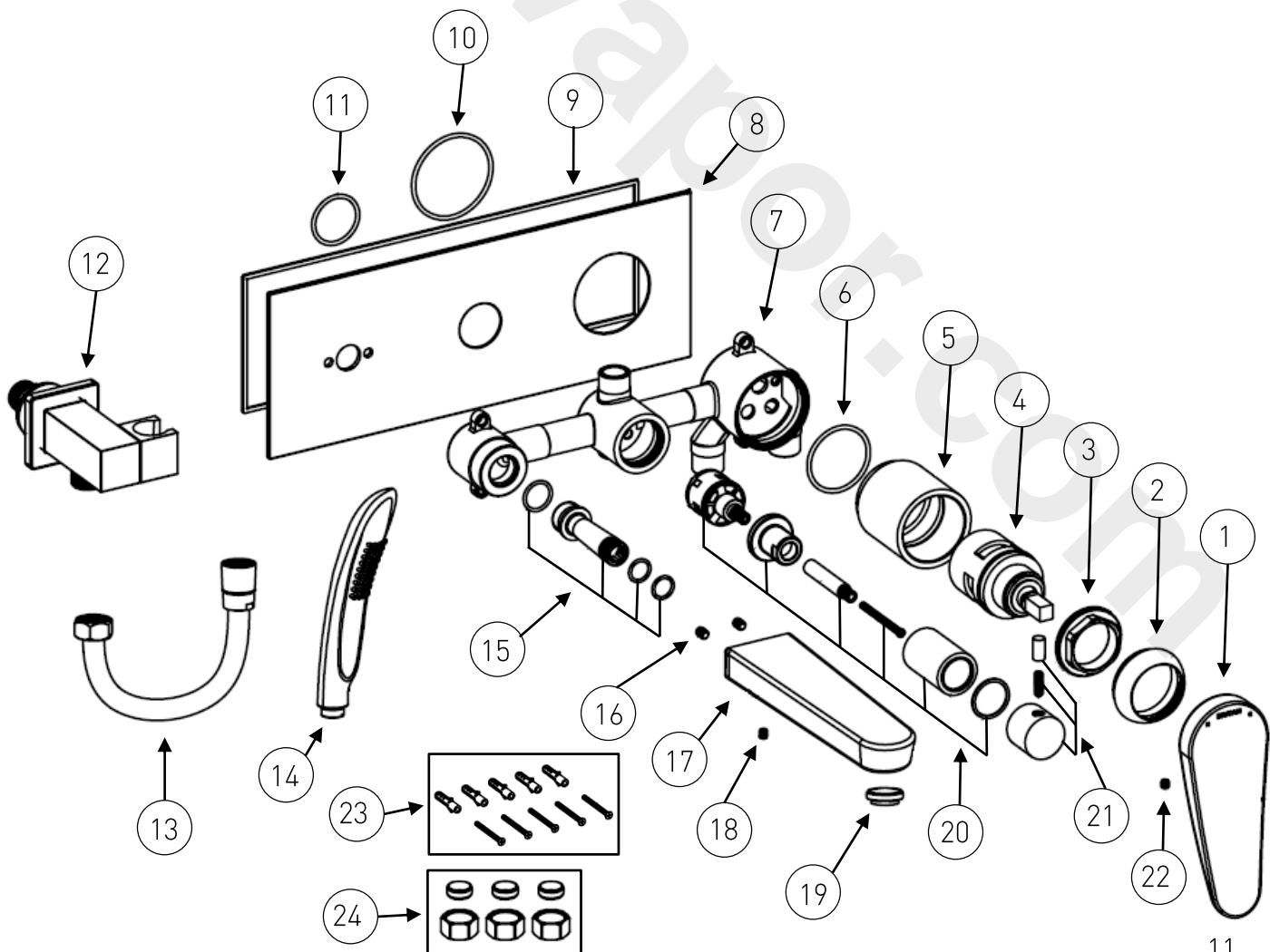

## Installation cont.

### Wall Outlet

There are two methods of fixing the wall outlet depending on the type of wall.

a: With rear access once wall is finished

Remove the brass backnut from the threaded tail, and insert the wall outlet through a 25-30mm hole in the wall and secure with backnut.

**TIP:** Use a thin line of silicone based sealant around the back edge of the concealing plate to create a tight water seal.

Connect the wall outlet assembly to the shower valve outlet (connection not supplied).

b: Without rear access once wall is finished

Fit a 'wall plate elbow' (not supplied) within the wall cavity and plumb in from the shower valve. Screw the threaded connecting tube (3) into the 'wall plate elbow' using a suitable thread sealant. The threaded connecting tube thread (3) must protrude from the finished wall by 5-15mm. Once the wall has been finished the wall outlet (4) and washer (2) can be fitted to the threaded connecting tube, using a suitable thread sealant.

**NOTE:** The backnut (1) is not required

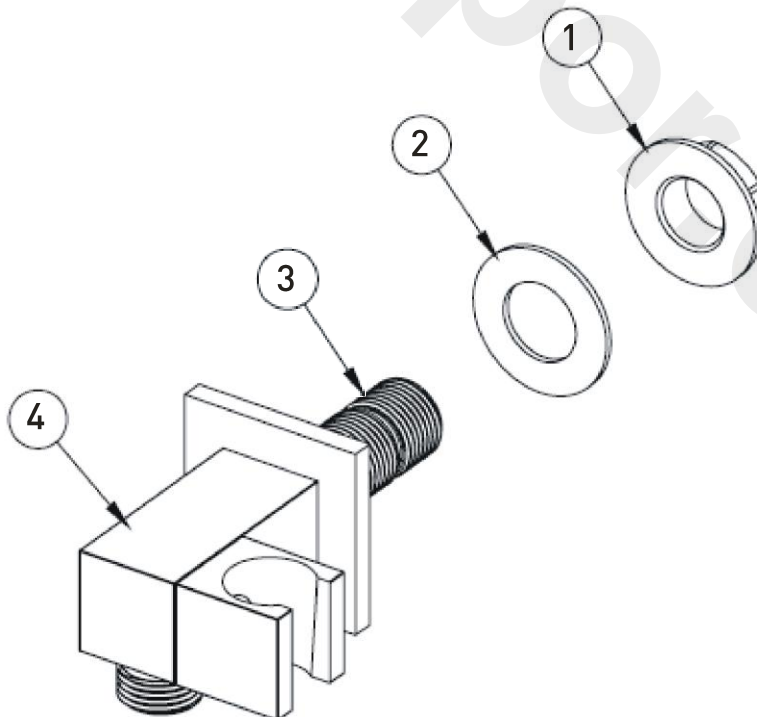

## Maintenance

### General Cleaning

Your fitting has a high quality finish and should be treated with care to preserve the visible surfaces. All finishes will wear if not cleaned correctly. The only safe way to clean your product is to wipe with a soft damp cloth. Stains can be removed using washing up liquid. All bathroom cleaning products (powders and liquids) will damage the surface of your fitting, even the non-scratch cleaners.

**Note:** Never use abrasive detergents or disinfectants or those containing alcohol, hydrochloric acid or phosphoric acid.



Bristan recommend E-cloth for cleaning all of our bathroom & kitchen products. Using just water, E-cloth gives a

smear free, deep clean by breaking up and holding dirt, which normal cloths leave behind. Order through your Bristan stockist (order code: E CLOTH).

We advise that your fitting is regularly serviced in hard water areas to maintain optimum performance.

See map of Hard Water Regions in the UK on page 16 to see the water type in your area.

### Cleaning the Showerhead: CLR WMBSM C

Your Bristan showerhead has rub-clean nozzles for easy cleaning. Simply rub your fingers across the rubber spray jets regularly and before you turn the shower on to remove any scale or debris.

The hardness of the water in your area will determine how often you should clean your showerhead. Build up of scale in particularly hard water areas combined with constant use means you may need to clean your showerhead once a week. To ensure continued performance the showerhead needs to be regularly descaled.

**Tip:** If the showerhead is heavily scaled or has not be maintained for a long period of time a solution of hot water and white vinegar may be needed to clear the scale.

Mix a 50/50 solution and rub the nozzles thoroughly with the solution making sure the solution gets into all of the nozzles.

Wash off the solution with clean water.

## Maintenance cont.

### Cleaning the Cartridge

If your fitting begins to leak the following should be carried out;

Isolate both hot and cold water supplies to the tap by either:

- Turning the water supply off at the mains stopcock or
- Turning off the isolation valves to the tap.

1. Remove the grub screw, located at the rear of the handle using a hexagonal key.
2. Remove the handle by pulling upwards from the spacer; proceed to remove spacer and shroud.
3. Using a suitable spanner remove retaining nut to gain access to the cartridge.
4. Lift out the cartridge and clean thoroughly. Be sure to check and clean out the seating within the tap body.
5. If necessary replace the cartridge.

Please visit [www.bristan.com/sparesfinder](http://www.bristan.com/sparesfinder) in order to find spare parts for this product.

6. Place the cartridge into the tap body and tighten the retaining nut fully using a suitable spanner.
7. Replace shroud, spacer and handle, ensuring to refit the grub screw.
8. Turn on water supply and check for leaks.
9. Contact our helpline should if problem persists.

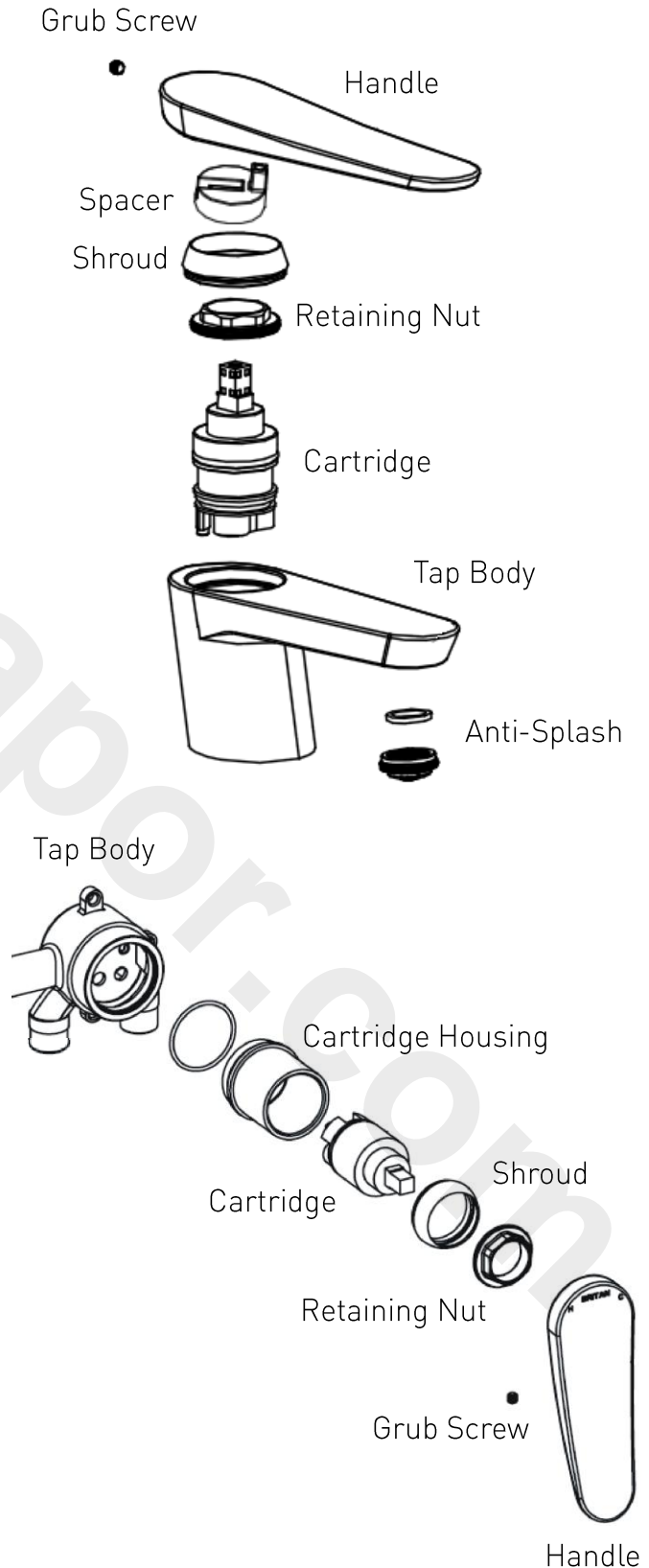

## Troubleshooting

Symptom	Cause	Remedy
No flow or poor flow rate.	Partially closed stop or service valve in water supply pipework to the tap.	Open stop or service valve.
	Head of water is below the minimum distance required.	Refer to the Specification section for minimum pressures required.
	Possible airlock / blockage in supply pipework	Remove water supplies from the fitting and flush the system to remove any airlocks / debris.
	Cartridge not opening fully.	Service fitting. Refer to maintenance section on pages 13-14.
Water dripping for a few seconds after the tap has been turned off.	This is caused by 'capillary action' and residual water in the spout being siphoned out. This should only last for a couple of seconds.	
Constant dripping / leaking when the tap is not in use.	Cartridge / Valve not fully shutting off.	Service fitting and replace cartridge. Refer to maintenance section on page 13-14.
Fitting does not turn on.	Water supplies not turned on.	Check that the water supplies to the fitting are turned on.
	Closed stop or service valve.	Open stop or service valve.
Water does not come out of the showerhead when using the bath shower mixer.	Diverter mechanism not fully open.	Turn the diverter mechanism into the appropriate position.
	Insufficient water pressure / header height.	Refer to the specification section for minimum pressures required.

## Map of Hard Water Regions in the UK



Soft to moderately soft  
0 - 100mg/l as calcium carbonate equivalent



Slightly hard to moderately hard  
100 - 200mg/l as calcium carbonate equivalent



Hard to very hard  
Above 200mg/l as calcium carbonate equivalent

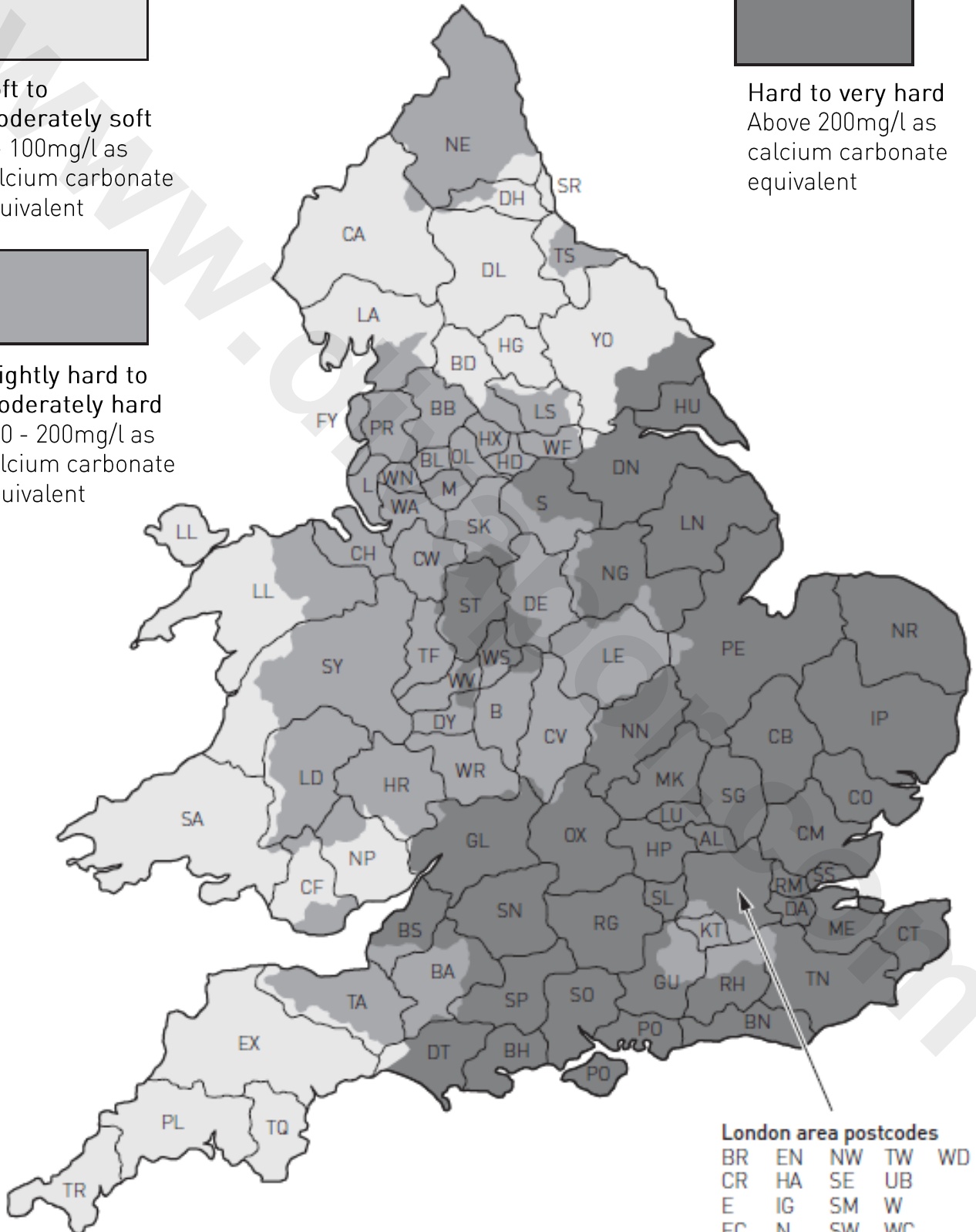



## Taps and Mixers

At Bristan, we want to make things as easy as possible for our customers. That's why we design products that are easy to fit and use, and that are quality tested to make sure they won't let you down. It's also why we offer solid guarantees on all products, effective from the date of purchase, to give you peace of mind.



**Guarantee**

All Bristan taps and mixers are covered by a **5 year guarantee**. This also includes **1 year labour cover\*** which means that, in the unlikely event that you should encounter a problem in the first year after purchase, we'll send one of our expert engineers to fix it.

\*Labour is provided by an approved Bristan Care engineer or appointed representative. The guarantee only applies to products with a manufacturing fault. There will be a call out charge for any incidents where no fault has been found with the product, or if the issue is due to poor installation or maintenance.

## Register Now and Extend Your Cover

Register your tap/mixer with us now and we'll extend your labour cover to **2 years – FREE!**

You can register quickly and easily online at [www.bristan.com/register](http://www.bristan.com/register). Alternatively, please fill in the details on the enclosed registration card and post it back to us.

## Guarantee Terms and Conditions

This guarantee is in addition to your statutory and other legal rights and is subject to the following conditions:

- The product was purchased within the United Kingdom or Republic of Ireland.
- The product is used in domestic applications only. For commercial or non-domestic applications such as leisure centres, sports clubs, hotels, premises operating as a business, the guarantee period is reduced to 1 year.
- The guarantee applies solely to the original purchaser with proof of purchase.
- The installation must allow ready access to all products for the purpose of inspection, maintenance or replacement.
- Repair under this guarantee does not extend the original expiry date. The guarantee on any replacement parts or product ends at the original expiry date.
- Any part found to be defective during the guarantee period will be replaced without charge, providing that the product has been installed in accordance with the instructions given in this guide and used as the manufacturer intended.

## The Guarantee Does Not Cover:

- Damage or defects caused by
  - General wear and tear (including special non-chrome finishes; components such as filters, seals, 'O' rings and washers)
  - Incorrect installation
  - Repair using non-Bristan parts
  - Accidental or wilful misuse
  - Corrosion and the use of inappropriate cleaning products.
  - System debris including the build up of limescale (which can be controlled through regular servicing and maintenance)
- Compensation for loss of use of the product or consequential loss of any kind.

In the interests of continuous product improvement, Bristan reserves the right to alter product specifications without notice.

The Bristan Product Guarantee does not affect your statutory rights as a consumer.

## **Need help?**

If your product does not function correctly when you first use it, contact your plumber and make sure that it has been installed and commissioned in line with the instructions in this guide. If this doesn't solve the problem, then please visit [www.bristan.com/bristancare](http://www.bristan.com/bristancare) for some helpful hints and tips, or contact **Bristan Care Customer Service on 0844 701 6273** where our expert team of advisors will be able to offer you, or your plumber, help and advice.

## Bristan Guarantee Cont.

### Taps and Mixers

#### Problems during the guarantee period

In the unlikely event that you encounter any problems with the product during the guarantee period, contact **Bristan Care Customer Service on 0844 701 6273** with your proof of purchase or unique guarantee registration number, and we will work to resolve the problem quickly.

#### Extended Guarantees

If your product is out of its guarantee period, or you would like to extend the guarantee, then please visit [www.bristan.com/customerservice](http://www.bristan.com/customerservice) for extended guarantee options.

#### Bristan Care Customer Support

Bristan customers also benefit from the support of Bristan Care, our comprehensive customer support package which offers:

**Technical support hotline** (Tel: 0844 701 6273) with access to fully trained advisors who can offer installation advice, talk you through quick maintenance checks, or recommend the best course of action to fix any problems with a product

**Expert advice** Find easy to follow 'how to' video guides and technical FAQs online at [www.bristan.com](http://www.bristan.com). Our guides take you step-by-step through many product installations and you can find plenty of easy guides to quick product fixes and servicing.

**Spare parts** We hold thousands of spares and we keep them for discontinued products for over seven years. Spares can easily be ordered online at [www.bristan.com](http://www.bristan.com) and are dispatched the same day.

**Expert plumbing engineers** If we can't solve the problem over the phone or with a spare part, then we'll send out one of our Bristan Care engineers to take a look. Bristan Care engineers provide free support for products that are within guarantee, but are also available to service products that are out of guarantee for a small charge. For details, please call customer services on 0844 701 6273.



**Guarantee**

## NOTES:

Please use this page to add any notes which you, or your installer may have regarding the installation / servicing of this product:

[www.divapor.com](http://www.divapor.com)

# BRISTAN

This booklet covers product codes

CLR BASNW C

CLR 1HBF C

CLR WMBAS C

CLR WMBF C

CLR WMBSM C

**Helpline**

**0844 701 6273**

Bristan Group Limited

Birch Coppice Business Park, Dordon, Tamworth, Staffordshire B78 1SG

A Masco Company

Website: [www.bristan.com](http://www.bristan.com)

Telephone: 0844 7016 274      Facsimile: 0844 701 6275

Email: [enquire@bristan.com](mailto:enquire@bristan.com)